

TASK FOUR PUZZLE SHEET

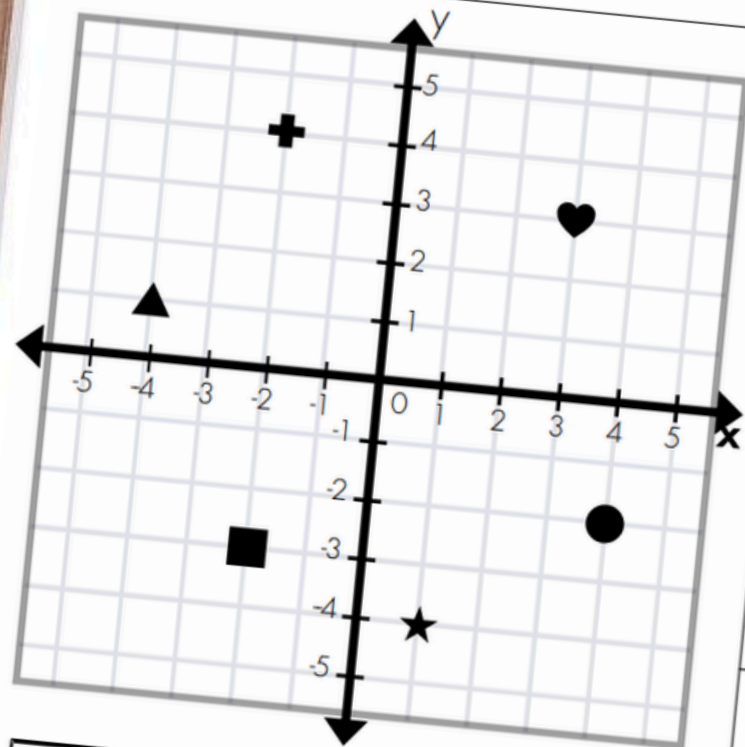

1			2			3		
(2,2)	(3,3)	(0,3)	(-2,4)	(4,-2)	(2,4)	(0,4)	(4,-2)	(2,4)
H	W	B	I	C	V	F	N	O

4			5			6		
(2,3)	(-3,2)	(-2,-3)	(-1,4)	(4,1)	(-4,1)	(1,-4)	(0,-4)	(-4,1)
A	E	N	G	L	E	R	X	B

CODE:

NEGATIVE
INTEGERS
ESCAPE ROOM

Keep scrolling to see what's included!

WANT A FUN WAY TO PRACTISE NEGATIVE INTEGERS ON A NUMBER LINE AND CARTESIAN PLANE WITH TEAMWORK?



Encourages teamwork, communication, and collaboration through engaging, hands-on group activities.



Strengthens addition and subtraction skills with stimulating tasks aligned to the Australian Curriculum v9.0.



No prep needed — simply print the sheets and share the Google Form link for easy, no-marking implementation.



TOY MAKER RESCUE

The Toy Factory's opening is near, but disaster has struck! The master creator...

The only way to...

The master c... instr...

TASK ONE DECODER

QUESTION 1 DECODER									
-2	0	3	-1	5	1	5	2	-3	4
R	E	Y	W	B	T	C	O	S	G
QUESTION 1 <input type="text"/> <input type="text"/> <input type="text"/>									

QUESTION 2 DECODER									
-3	1	0	3	-2	5	-1	4	-5	2
N	O	C	D	B	A	U	P	S	X
QUESTION 2 <input type="text"/> <input type="text"/> <input type="text"/>									

QUESTION 3 DECODER									
0	2	6	3	-6	4	-3	-4	1	-2
A	H	S	R	W	E	M	I	O	P
QUESTION 3 <input type="text"/> <input type="text"/> <input type="text"/>									

QUESTION 4 DECODER									
-4	5	0	2	-3	1	-1	6	-2	4
X	B	E	T	C	L	U	N	J	D
QUESTION 4 <input type="text"/> <input type="text"/> <input type="text"/>									

CODE:

WHAT'S INCLUDED?

- Four Rigorous Tasks That Develop Problem-Solving Skills And Logic!
- Exclusive Access To An Original Video That Sets The Scene (Check Out The Video Preview!)
- Self-Checking/Marking Google Form – No Teacher Marking Required!
- Digital (Google Slide) Version Of Activities Available



HOW DOES IT WORK?

- 1 Divide students into groups of 3 or 4.
- 2 Provide all groups with pages 8 - 16 in a plastic sleeve or folder.
- 3 Share the Google Form, either through Google Classroom or by writing the link on your board.
- 4 Ensure 1 person in the group has an iPad or access to a computer, so students can access the Google Form and check their answers are correct
Note: Students cannot progress to the next task until their answer is typed correctly in the Google Form
- 5 Display page 7 to set the scene, or watch the video linked on page 6, then you're ready to go!



THE SYDNEY TEACHER

TASK THREE

SUPPLIES NEEDED:

- Task 3

DIRECTIONS:

1. Match
2. As y
3. Type

no sp

THE SYDNEY TEACHER

TASK FOUR

SUPPLIES NEEDED:

- Task 4 Puzzle Sheet

DIRECTIONS:

1. Identify the correct position for all shapes on the Cartesian Plane, circling the answer on the table
2. Match each answer to its corresponding letter, and record this in the space below
3. Type the secret code in CAPITAL letters into the Google Form with no spaces. If the code is correct, you did it!

PRINTABLE AND DIGITAL

TASK THREE PUZZLE SHEET

(2,1)	
(1,-2)	
(1,1)	
(1,-1)	

A	Start at (2,3) then move 2 spaces down and 1 space left.
B	Start at (-1,-2) then move 3 spaces up and 3 spaces right.
C	Start at (
D	Start at (

Print and go!

Digital Option!

TASK TWO

SUPPLIES NEEDED:

- Task 2 Puzzle Sheet

TASK ONE ANSWERS CONT.

QUESTION 1 DECODER									
-2	0	3	-1	5	1	5	2	-3	4
R	E	Y	W	B	T	C	O	S	G
QUESTION 1	T	O	Y						

QUESTION 2 DECODER									
-3	1	0	3	-2	5	-1	4	-5	2
N	O	C	D	B	A	U	P	S	X
QUESTION 2	B	O	X						

QUESTION 3 DECODER									
0	2	6	3	-6	4	-3	-4	1	-2
A	H	S	R	W	E	M	I	O	P
QUESTION 3	R	E	S						

QUESTION 4 DECODER									
-4	5	0	2	-3	1	-1	6	-2	4
X	B	E	T	C	L	U	N	J	D
QUESTION 4	C	U	E						

CODE: T O Y B O X R E S C U E

TRUE or FALSE
 Write T for true or F for false for each
 Enter the code into the Google Form with
 the code to the next task

TASK TWO PUZZLE SHEET

8	<	5	TRUE	FALSE
-2	>	-4	TRUE	FALSE
0	<	2	TRUE	FALSE
-5	>	0	TRUE	FALSE
4	>	-6	TRUE	FALSE
-3	<	1	TRUE	FALSE

CODE: [] [] [] [] [] [] [] []

HOW YOU CAN USE THIS RESOURCE

This escape room is perfect for...



Help your students develop effective communication skills and team work



Make an engaging whole class reward



Build confidence and mastery of essential maths skills through structured hands-on practice

THE SYDNEY TEACHER

TASK ONE ANSWERS

QUESTION 1		1	2
QUESTION 2		-2	1
QUESTION 3		3	4
QUESTION 4		-3	-1

THE SYDNEY TEACHER

HAVE YOU SEEN THIS?



"Very engaging, my students love a good maths escape room. The way it is presented kept all students engaged and fostered positive group work skills."

-Damien F.



ADDITION & SUBTRACTION ESCAPE ROOM

THE SYDNEY TEACHER

TASK THREE QUESTION SHEET

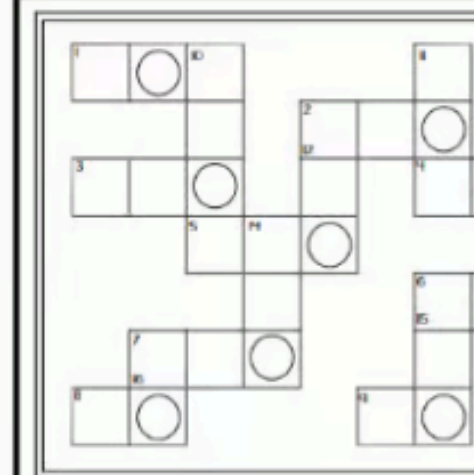

CODE: _ _ _ _

TASK ONE QUESTION SHEET

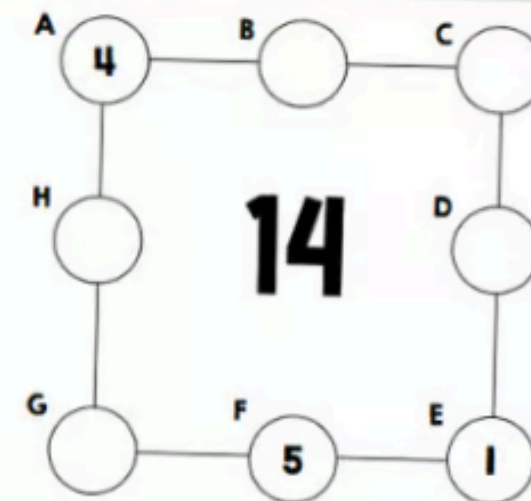

CODE: 4 _ _ 15 _ _

YEARS 3&4 ALIEN ABDUCTION!